

## SELECTION OF THE OPTIMAL MACHINERY COMPLEX FOR CONSTRUCTING IRRIGATION CANALS WITH A PARABOLIC PROFILE

Zh.N. Moldamuratov<sup>1,2,\*</sup> , M.N. Sennikov<sup>3</sup> , O.D. Seitkazinov<sup>1</sup> , G.S. Abieva<sup>1</sup> ,  
Zh.E. Yeskermessov<sup>3</sup> 

<sup>1</sup>International Educational Corporation, 050043, Almaty, Kazakhstan

<sup>2</sup>Peter the Great St. Petersburg Polytechnic University, 195220, St. Petersburg, Russian Federation

<sup>3</sup>M.Kh. Dulaty Taraz Regional University, 080000, Taraz, Kazakhstan

---

**Abstract.** *An analysis of the experience of dredger operation in various industries allows us to identify the following main problems that need to be addressed to improve their efficiency: improvement of papillation schemes and structural enhancement of the main equipment from a hydraulic perspective. The current soil intake devices, suction lines, and soil pumps do not always fully meet the specific requirements of soil development conditions. The objectives of the present research were to propose ways to enhance the performance of systems for automatic control of dredger work movements and automatic regulation of the soil intake process. These proposals aim to create a parabolic cross-sectional shape of the canal during development, ensure the highest productivity and lowest energy consumption, as well as low work costs, using modern control devices. The effect of the proposed technology for canal development using dredgers with automated papillation consists of the following: providing the developed canals with a stable cross-sectional shape; automating the papillation of the dredger and optimizing the operation of the soil pump; Implementing shift-based production accounting; using soil meters in the automated system. Giving the developed canal a cross-sectional shape that is stable in both hydraulic and static aspects has allowed for the following benefits: increased sediment transport capacity of the flow, while simultaneously reducing the cross-sectional area, growth of vegetation, water level fluctuations, water losses, and the right-of-way strip; reduced the volume of cleaning work by up to 20%; increased the period between cleanings by ensuring uniform flow movement; enhanced the productivity of dredgers by concentrating sediment on the canal slopes without changing the overall volume of cleaning.*

**Keywords:** *irrigation canals, dredging shells, slopes, cleaning, reconstruction and repair.*

---

**\*Corresponding author**

**Zhangazy Moldamuratov**, e-mail: zhanga\_m\_n@mail.ru

<https://doi.org/10.51488/1680-080X/2024.2-11>

Received 14 February 2024; Revised 19 March 2024; Accepted 04 June 2024

ӘОЖ 624.012.44  
ҒТАМР 70.21.15  
ҒЫЛЫМИ МАҚАЛА

## ПАРАБОЛА ПІШІНДІ СУАРУ КАНАЛДАРЫН САЛУҒА АРНАЛҒАН ОҢТАЙЛЫ МАШИНАЛАР КЕШЕНІН ТАҢДАУ

Ж.Н. Молдамұратов<sup>1,2,\*</sup> , М.Н. Сенников<sup>3</sup> , О.Д. Сейтқазинов<sup>1</sup> , Г.С. Абиева<sup>1</sup> ,  
Ж.Е. Ескермесов<sup>3</sup> 

<sup>1</sup>Халықаралық білім беру корпорациясы, 050043, Алматы, Қазақстан

<sup>2</sup>Ұлы Петр Санкт-Петербург политехникалық университеті, 195220,  
Санкт-Петербург, Ресей Федерациясы

<sup>3</sup>М.Х. Дулати атындағы Тараз өңірлік университеті, 080000, Тараз, Қазақстан

**Андатпа.** Әр түрлі салалардағы жерсорғы снарядтарын пайдалану тәжірибесін талдау олардың тиімділігін арттыру алдында тұрған келесі негізгі проблемаларды анықтауға мүмкіндік береді: папиллондау схемаларын жетілдіру; гидравлика тұрғысынан негізгі жабдықты конструктивті жақсарту. Қазіргі уақытта қолданыстағы жерсорғы желілері, топырақ сорғылары әрдайым топырақты игеру шарттарының нақты талаптарына толық сәйкес келе бермейді. Осы зерттеулердің міндеттері арнаны тазалау процесінде көлденең қиманың параболалық пішінін беруге, ең жоғары өнімділік пен ең аз энергия сыйымдылығын, сондай-ақ заманауи бақылау құралдарын пайдалана отырып, жұмыстың төмен құнын қамтамасыз етуге мүмкіндік беретін жерсорғы снарядының жұмыс қозғалыстарын автоматты басқару жүйелерінің жұмыс қабілеттілігін арттыру және топырақ жинау процесін автоматты реттеу ұсыныстары болды. Автоматтандырылған папиллондауы бар жерсорғыш снарядтармен арналарды әзірлеудің ұсынылған технологиясының әсері мыналардан тұрады: тазаланып жатқан арналарға тұрақты көлденең қима пішінін беру; жерсорғы снарядының папиллонажын автоматтандыру және топырақ сорғысының жұмысын оңтайландыру; сорғының ауысымдық есебін қолдану; автоматтандырылған жүйеде топырақ өлшегіштерді пайдалану. Тазаланып жатқан арнаға гидравликалық және статикалық тұрғыдан тұрақты көлденең қима пішінін беру: көлденең қиманың ауданын, өсуін, су деңгейінің ауытқуын және шығынын, сондай-ақ иеліктен шығару жолағын азайта отырып, ағынның құмды тасымалдау қабілетін арттыруға; тазарту жұмыстарының көлемін 20% - ға дейін азайтуға; ағынның біркелкі қозғалысын қамтамасыз ету есебінен тазарту кезеңін ұлғайтуға; жерсорғы снарядтарының өнімділігін арттыруға мүмкіндік береді.

**Түйін сөздер:** суару каналдары, жерсорғы снарядтары, беткейлер, тазарту, қайта жаңғырту және жөндеу.

\*Автор-корреспондент

Жанғазы Молдамұратов, e-mail: zhanga\_m\_n@mail.ru

<https://doi.org/10.51488/1680-080X/2024.2-11>

Алынды 14 ақпан 2024; Қайта қаралды 19 наурыз 2024; Қабылданды 04 маусым 2024

## ВЫБОР ОПТИМАЛЬНОГО КОМПЛЕКСА МАШИН ДЛЯ СТРОИТЕЛЬСТВА ОРОСИТЕЛЬНЫХ КАНАЛОВ ПАРАБОЛИЧЕСКОГО ПРОФИЛЯ

Ж.Н. Молдамуратов<sup>1,2,\*</sup> , М.Н. Сенников<sup>3</sup> , О.Д. Сейтказинов<sup>1</sup> , Г.С. Абиева<sup>1</sup> ,  
Ж.Е. Ескермесов<sup>3</sup> 

<sup>1</sup>Международная образовательная корпорация, 050043, Алматы, Казахстан

<sup>2</sup>Санкт-Петербургский политехнический университет Петра Великого, 195220,  
Санкт-Петербург, Российская Федерация

<sup>3</sup>Таразский региональный университет имени М.Х. Дулати, 080000, Тараз, Казахстан

---

**Аннотация.** Анализ опыта эксплуатации земснарядов в различных отраслях позволяет выявить следующие основные проблемы, стоящие перед повышением их эффективности: совершенствование схем папильонирования; конструктивное улучшение основного оборудования с точки зрения гидравлики. Существующие в настоящее время грунтозаборные устройства, всасывающие линии, грунтонасосы не всегда полностью отвечают конкретным требованиям условий разработки грунта. Задачами настоящих исследований были предложения повысить работоспособность систем автоматического управления рабочими перемещениями земснаряда и автоматического регулирования процесса грунтозабора, позволяющие в процессе разработки канала придать параболическую форму поперечного сечения, обеспечить наивысшую производительность и наименьшую энергоемкость, а также низкую себестоимость работ, используя современные приборы контроля. Эффект от предложенной технологии разработки каналов землесосными снарядами с автоматизированным папильонированием складывается из следующего: придание разрабатываемым каналам устойчивой формы поперечного сечения; автоматизации папильонажа земснаряда и оптимизации работы грунтового насоса; применение посменного учета выработки; использование в автоматизированной системе грунтомеров. Придание разрабатываемому каналу устойчивой в гидравлическом и статическом отношении формы поперечного сечения позволило: повысить наносотранспортирующую способность потока, при одновременном снижении площади поперечного сечения, зарастания, колебания уровня и потерь воды, а также полосы отчуждения; уменьшить объем очистных работ до 20%; за счет обеспечения равномерного движения потока увеличить межочистный период; повысить производительность земснарядов за счет сосредоточения наносов на откосах канала при неизменности общего объема очистки.

**Ключевые слова:** оросительные каналы, землесосные снаряды, откосы, очистка, реконструкция и ремонт.

---

\*Автор-корреспондент

Жангазы Молдамуратов, e-mail: zhanga\_m\_n@mail.ru

<https://doi.org/10.51488/1680-080X/2024.2-11>

Поступило 14 февраля 2024; Пересмотрено 19 марта 2024; Принято 04 июня 2024

### **ACKNOWLEDGEMENTS/SOURCE OF FUNDING**

The study was financially supported by the Committee of Science of the Ministry of Science and Higher Education of the Republic of Kazakhstan as part of the scientific project No. AP13268964.

### **CONFLICT OF INTEREST**

The authors state that there is no conflict of interest.

---

### **АЛҒЫС / ҚАРЖЫЛАНДЫРУ КӨЗІ**

Зерттеуге Қазақстан Республикасы Ғылым және Жоғары Білім Министрлігінің Ғылым Комитеті №AP13268964 ғылыми жоба аясында қаржылай қолдау көрсетілді.

### **МҮДДЕЛЕР ҚАҚТЫҒЫСЫ**

Авторлар мүдделер қақтығысы жоқ деп мәлімдейді.

---

### **БЛАГОДАРНОСТИ/ИСТОЧНИК ФИНАНСИРОВАНИЯ**

Исследование было проведено при финансовой поддержке Комитета науки Министерства науки и высшего образования Республики Казахстан в рамках научного проекта № AP13268964.

### **КОНФЛИКТ ИНТЕРЕСОВ**

Авторы заявляют, что конфликта интересов нет.

## 1 INTRODUCTION

The basis of rational technology and work organization is the comprehensive mechanization of all tasks with the best technical and economic indicators. In this case, all labor-intensive main and auxiliary operations of the technological process must be performed by a machine or a complex of machines. The use of machines in the construction or reconstruction of canals should ensure the highest labor productivity under specific conditions, at the lowest cost and shortest duration of work (Novruzova, 2023).

It should be noted that in the comprehensive mechanization of tasks, the productivity of the entire complex is determined by the productivity of the leading machine (Kadirova, 2023). Other machines involved in performing auxiliary operations and included in the complex should be interrelated by main parameters in such a way as to ensure the uninterrupted operation of the entire complex. The complex should include the minimum number of machines for the given specific working conditions (Wen et al., 2014). The use of machines in construction should be determined by the actual operational productivity and duration of working time (Usmonov et al., 2023). The working time of machines should include the duration of performing technological process operations, moving under their own power along the work front within one construction site or from one site to another, technological breaks in the work of machines, preparation of machines for work at the beginning of the shift and handing them over at the end of the shift, technical maintenance of machines during the shift, and the regulated rest period for the operator during the shift (Novruzova, 2022).

To quantitatively equip the machines needed to carry out the construction or reconstruction of irrigation canals, it is necessary to determine the required number of machine-hours that allow completing the work on the site (Rakhmanin et al., 2020). Then, all work operations should be divided into groups, considering the possibility of performing each operation or group of operations independently of each other in time, but with the necessary technological sequence (Zebardast et al., 2015). This division will make it easier to coordinate the number of machines in each group of operations. If there is no need to perform several operations simultaneously, each can be performed by one machine after the completion of the previous process (Novruzova, 2023).

## 2 LITERATURE REVIEW

Technological machine complexes recommended for the construction and reconstruction of rational profile canals in inter-farm and intra-farm networks (Rakhmanin et al., 2020):

1. For irrigation network canals with a depth of up to 1.5 meters, an excavator-ditch digger with a swinging rotor based on the K-701 tractor is recommended.
2. For canals with a depth of 2 to 3 meters, screw-rotor ditching excavators of the ETR-207 type are suitable.
3. For irrigation network canals with a parabolic profile, reclamation dredgers with selected technical characteristics are recommended.

It is advisable to carry out the work for constructing canals with a parabolic cross-section using a flow method (Cheng et al., 2022). This method ensures the even loading of all mechanisms during the work shift. The main features of flow construction are uniform and continuous production, based on the segmentation of the overall production process, division of labor, combination, and rhythm of work processes (Naumova et al., 2019).

To enhance the level of mechanization and the efficiency of using machine complexes in the construction of irrigation networks with a full range of canal sizes, it is crucial to correctly justify the choice of their sizes and ensure the flow execution of work with minimal costs (Lee et al., 2020).

For the construction of rational profile canals, three technological construction schemes with the use of rotor excavator-ditcher working bodies have been developed:

1. Scheme 1 – with a dual-rotor type working body (Figure 1a).
2. Scheme 2 – with a swinging type rotor working body (Figure 1b).
3. Scheme 3 – with a screw-rotor working body (Figure 2).

The distinctive features of the proposed schemes compared to existing excavator-ditcher working bodies are as follows:

- For Scheme 1 – the installation of rotors (cutters) in space with angles of inclination to the horizontal plane ( $\alpha$ ) and rotation in plan ( $\beta$ ) relative to the longitudinal axis of the machine, which together allows achieving a canal profile close to parabolic.

- For Scheme 2 – the swinging of the rotor during operation relative to the vertical axis, which, in combination with passive knives at the top of the slopes, allows obtaining a parabolic canal profile.

- For Scheme 3 – the structural features of conical screw side cutters, whose generatrix is made curvilinear (barrel-shaped), which, in combination with the rotor and the finishing blade, allows achieving a parabolic profile canal cross-section.

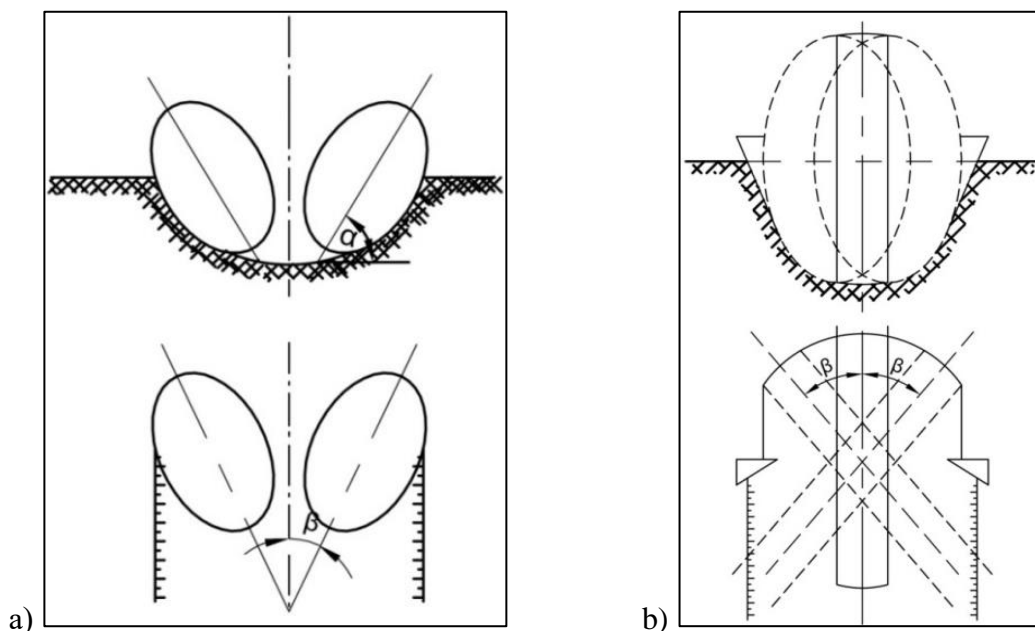

**Figure 1** - Schemes for developing a parabolic profile canal using a dual-rotor type ditcher working body (a) and a swinging rotor type ditcher working body (b) (author's material)

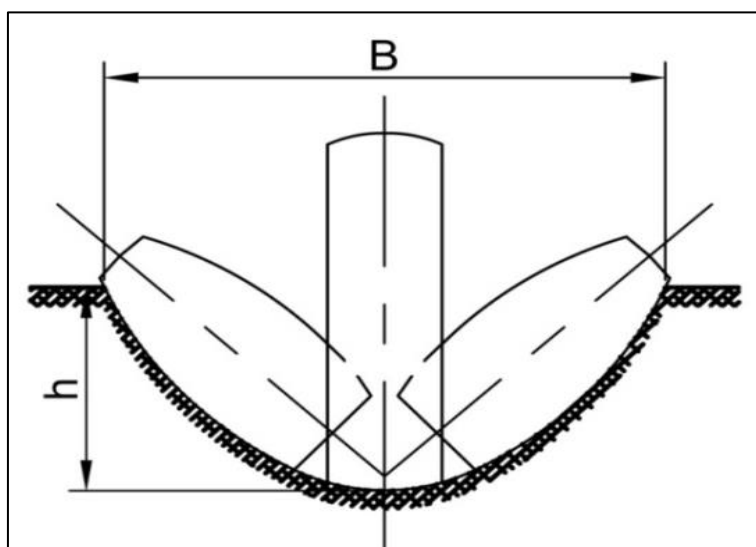

**Figure 2** - Scheme for developing a parabolic profile canal using a screw-rotor type ditcher working body (author's material)

By changing the angles of inclination and rotation of the rotors in the first scheme, the angle of swinging in the second scheme, and the inclination of the screw side cutters in the third scheme, not only can canals with different cross-sectional profiles be achieved, but the cross-sectional area of the



canal, machine productivity, energy consumption, as well as specific power and productivity costs are also affected (Bai et al., 2019). Understanding the influence of the angles of rotation and inclination of the rotor and screw on the indicators will allow for the selection of optimal operating modes for the working bodies when developing rational profile canals (Rakhmanin et al., 2020).

Figure 3 shows the dependence of soil cutting force  $P_z$  on the rotor rotation angle  $\beta$  at different values of the inclination angle  $\alpha$  for a bucket with an elementary profile cutting perimeter.

As is known (Moldamuratov, 2020), one of the main indicators of a machine is its productivity, which reflects the work process. For continuous operation excavators, productivity particularly depends on the efficiency of the digging process. Therefore, when optimizing the technological parameters of ditcher-excavators, the decisive factor determining the energy consumption of the machine is the determination of the loading dependence of the working bodies for various design parameters and the physical-mechanical properties of the soil (Rakhmanin et al., 2020).

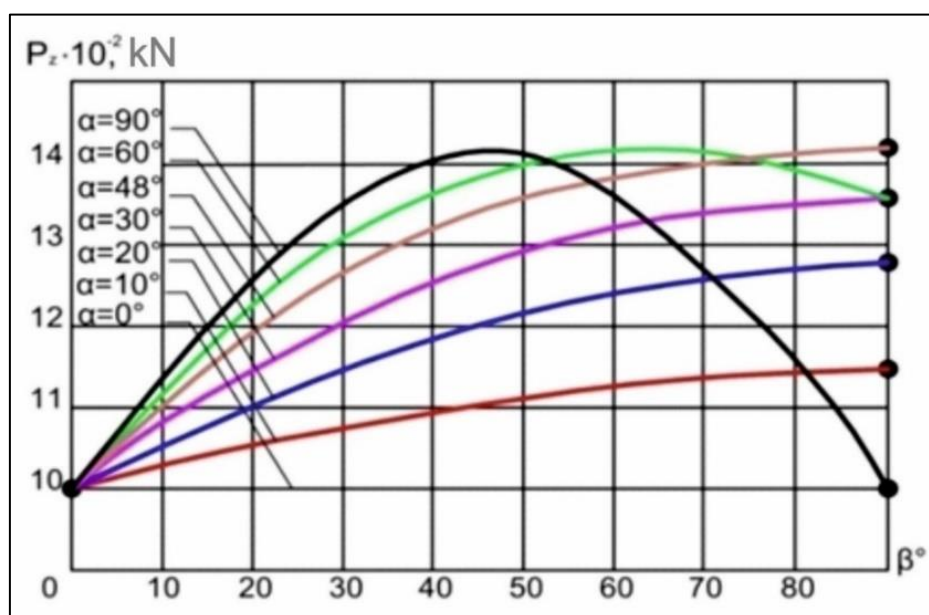

Figure 3 - Dependence of soil cutting force  $P_z$  on the change in rotor rotation angle  $\beta$  at different values of inclination angle  $\alpha$  for a bucket with a cutting perimeter of an elementary profile (author's material)

An analysis of the experience (Boutsioukis et al., 2022) of dredger operation in various industries allows us to identify the following main problems that need to be addressed to improve their efficiency:

- Improvement of papillation schemes. While the existing work movement schemes may somewhat satisfy soil development in quarries, they require further refinement for the conditions of developing profile excavations and especially for maintaining canals with curvilinear cross-sectional shapes in working condition.

- Creation of modern, reliable control and measuring equipment, particularly for monitoring soil intake processes, papillation, and production accounting.

- Automation of the papillation process.

- Enhancement of the suction capacity of dredgers by improving the working characteristics of soil pumps.

- Structural improvement of the main equipment from a hydraulic perspective. The current soil intake devices, suction lines, and soil pumps do not always fully meet the specific requirements of soil development conditions.

- Increasing the wear resistance of the equipment.

- Lack of a sufficient number of standard sizes of reclamation dredgers.

### 3 MATERIALS AND METHODS

In the practice of hydraulic construction and the operation of hydro-reclamation systems, the most widespread methods for constructing and cleaning canals from sediment involve using separate funnels and trenches. Several authors ([Boutsoukis et al., 2022](#)) believe that these methods of soil development create favorable suction conditions. The tip develops the soil around its entire perimeter, and the deeper it penetrates the deposits, the better the suction conditions become due to the formation of a funnel or trench, along the slopes of which particles slide towards the intake opening ([Wang et al., 2020](#)). This ensures a high consistency of the slurry, thereby increasing the dredger's productivity, measured in linear meters of canal developed per hour of pure work compared to other methods ([Rakhmanin et al., 2020](#)).

As production studies ([Pishgar et al., 2022](#)) have shown, the method of cleaning the canal with separate funnels has the following significant drawbacks:

- Uneven surface of the canal bottom after its development;
- Over-deepening of the canal bottom's design profile, leading to increased water filtration from the canal due to the removal of the colmatage layer (when cleaning canals from sediment);
- The inability to continuously bring the intake opening of the tip closer to the face, which practically, in the absence of consistency meters, leads to a decrease in the slurry's soil content;
- Relatively short working time (20-25% of the dredger's pure working time) of the soil pump with satisfactory slurry consistency (soil content around 10%);
- The possibility of using some looseners and other intensifiers for soil intake.

The cleaning of the canal with longitudinal trenches has found wide application in deepening works with large dredgers. In this method, dredgers without looseners develop the soil in separate trenches, moving forward along the designated cut ([Figure 4](#)). To fix the position of the dredger and perform its movements when working against the current, a bow anchor is brought forward, and two side anchors are placed. The trench method is characterized by its simplicity ([Rakhmanin et al., 2020](#)).

The disadvantages of the trench method for cleaning canals include:

- The ability to develop mainly light soils through free suction;
- Over-deepening of the cleaned canal bottom, which can lead to increased water filtration from the canal into the underlying soils;
- Increased volume of development due to the over-deepening of the canal bottom;
- Unfavorable suction conditions (part of the perimeter of the intake opening of the tip draws in clean water). This reduces the consistency of the slurry, and consequently, the productivity of the soil pump concerning the soil;
- The presence of idle movements, which reduces the utilization factor of the shift equipment and increases the cost of cleaning work.

Cleaning the canal using papillation strips is a progressive method. In this case, the soil intake device moves from one bank to the other across the canal, and the soil is developed with transverse trenches. When the dredger is equipped with a pile apparatus, pile papillation is used ([Figure 5](#)); in its absence, papillation on cables is used ([Moldamuratov, 2020](#)).



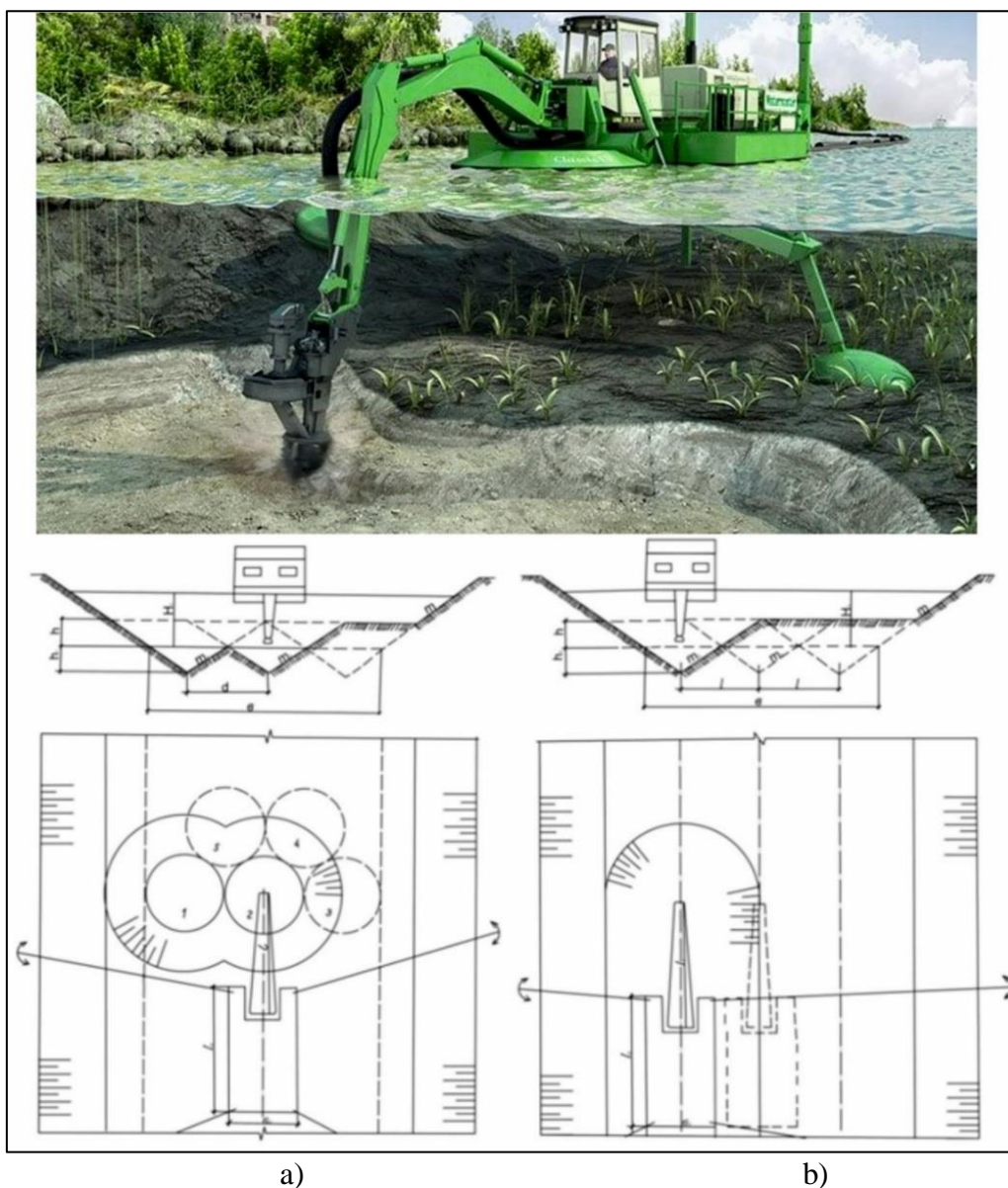

**Figure 4** - Soil development using separate funnels (a) and longitudinal trenches (b)  
(author's material)

#### 4 RESULTS AND DISCUSSION

The papillation scheme yields good results when developing dense soils of small thickness with the mandatory use of looseners. It provides a good finish for the canal bottom surface and, by eliminating idle movements, increases the utilization rate of shift equipment. In pile papillation, the dredger body turns by 350 - 450 degrees, which determines the width of the developed cut ([Rakhmanin et al., 2020](#)).

Thus, when cleaning canals of a given width using the trench scheme and separate funnels, the values of the over-deepening of the developed canal bottom and the volume of excess excavated soil decrease as the distance between adjacent trenches or funnels across the canal is reduced. However, as the distance between adjacent trenches or funnels decreases, the necessary number of trenches or funnels across the canal increases to achieve the design width of the developed canal bottom ([Figure 6a, b](#)). With many trenches or funnels in the cross-section of the canal, the time for the dredger's working movements will constitute a significant portion of the work shift, leading to a reduction in the utilization rate of working equipment during the shift, thus decreasing the productivity of the soil pump ([Shaazizov et al., 2020](#)).

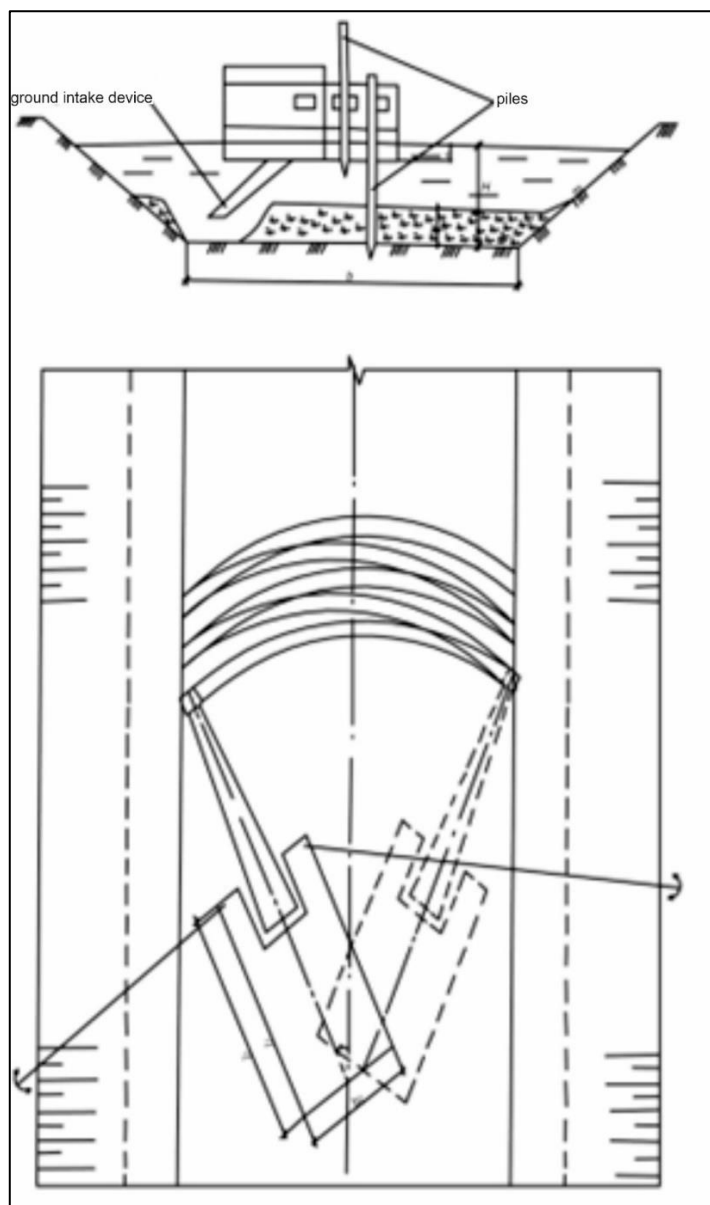

Figure 5 - Soil development using papillation strips (author's material)

Conversely, reducing the number of trenches and funnels in the canal cross-section leads to increased values of the canal bottom over-deepening and the volume of developed soil. Therefore, when setting the distances between adjacent trenches or funnels, these mutually opposing factors should be considered (Shaazizov et al., 2020).

When the lengths of the shore or floating slurry pipelines are equal for all three soil development schemes, and when developing narrow canals (with the slurry being discharged onto the shore by a slurry nozzle), the time spent moving the dredger for the trench scheme is greater than for separate funnels, due to the additional time required for returning the dredger to the initial development position. For the canal cleaning scheme with separate funnels, the time spent moving the dredger is greater than for the papillation scheme, as additional time is needed to move the suction slurry pipeline from one funnel to another. Thus, the papillation scheme requires the least time for non-productive movements (Tarasyants et al., 2021).

Production studies have shown (Shaazizov et al., 2020) that for removing a sediment layer up to 0.5 meters thick, it is not rational to use cleaning schemes with separate funnels and trenches.

Therefore, in the papillation canal cleaning scheme, the bottom over-deepening, the volume of excess excavated soil, and the non-productive time spent moving the soil intake device are minimized. Additionally, a relatively smooth surface of the canal bottom and slopes is ensured (Figure 6c).

The application of the papillation scheme allows for increased productivity of dredgers in terms of soil and especially the length of the developed canal. During canal cleaning, it simultaneously preserves the layer of colmatage soil (without increasing water loss in the canal due to filtration) and maintains the stability of the canal slopes after cleaning. The use of the papillation soil development scheme will reduce the extent of over-deepening of the canal bottom's design profile, thus mitigating the disadvantage inherent in the hydraulic mechanized method of soil development during the construction and maintenance of hydro-reclamation system canals (Rakhmanin et al., 2020).

The wetted perimeter of the canal after its development with longitudinal trenches is greater than that of the canal developed with papillation strips. The flow with the highest kinetic energy occurs in the canal with the smallest wetted perimeter. Therefore, the flow in the canal developed with papillation strips has a greater sediment transport capacity compared to the flow in the canal developed with longitudinal trenches and even more so after cleaning with separate funnels (Shaazizov et al., 2020).

The application of the papillation canal cleaning scheme will significantly improve the quality of work in the construction and maintenance of hydro-reclamation system canals, as it improves with the reduction in the magnitude of over-deepenings and under-excavations (Shaazizov et al., 2020).

Due to the small values of the wetted perimeter length and the canal width at the water's edge in parabolic cross-sections, there are fewer water losses due to filtration (especially for canals with sandy soil beds) and evaporation. Additionally, the operation of canals with an earth bed and a stable profile is 2-3 times cheaper than the operation of silted and eroded sections (Shaazizov et al., 2020).

The development of inter-farm canals with a curvilinear shape can only be performed by dredgers due to their placement within the developed canal during operation and the pendulum movement of the intake opening of the nozzle (Rakhmanin et al., 2020). The technology of the soil development scheme using a dredger is shown in Figure 7.

The technological parameters of cleaning schemes for various work methods are presented in Table 1, which allows for the selection of the optimal option and alignment with technological indicators (Figure 8).

**Table 1**

Establishing technological parameters for various work methods using dredgers [author's material]

Technological indicators	Cleaning schemes		
	Separate funnels	Longitudinal trenches	Papillation ribbons
Deepening of the canal bottom	$\frac{d}{2m_3} = \frac{b}{2nm_3}$	$\frac{l}{2m_3} = \frac{b}{2nm_3}$	$\frac{C}{2m_3}$
The volume of excessively excavated soil	$\frac{\pi db}{24m_3} = \frac{\pi b^2}{24nm_3}$	$\frac{bl}{4m_3} = \frac{b^2}{4nm_3}$	$\frac{Cb}{4m_3}$
The time spent on moving the dredger per 1 linear meter of the canal being cleaned	$\frac{t_1 b}{d^2} + \frac{t_1^n}{l_1}$	$\frac{(t_2 + t_2^n)b}{l^2} + \frac{t_2^n}{l_2}$	$\frac{t_3}{C} + \frac{t_3^n}{l_3}$
When the hydraulic mixture is discharged by a jet onto the shore	$\frac{t_1 b}{d^2}$	$\frac{(t_2 + t_2^n)b}{l}$	$\frac{t_3}{C}$

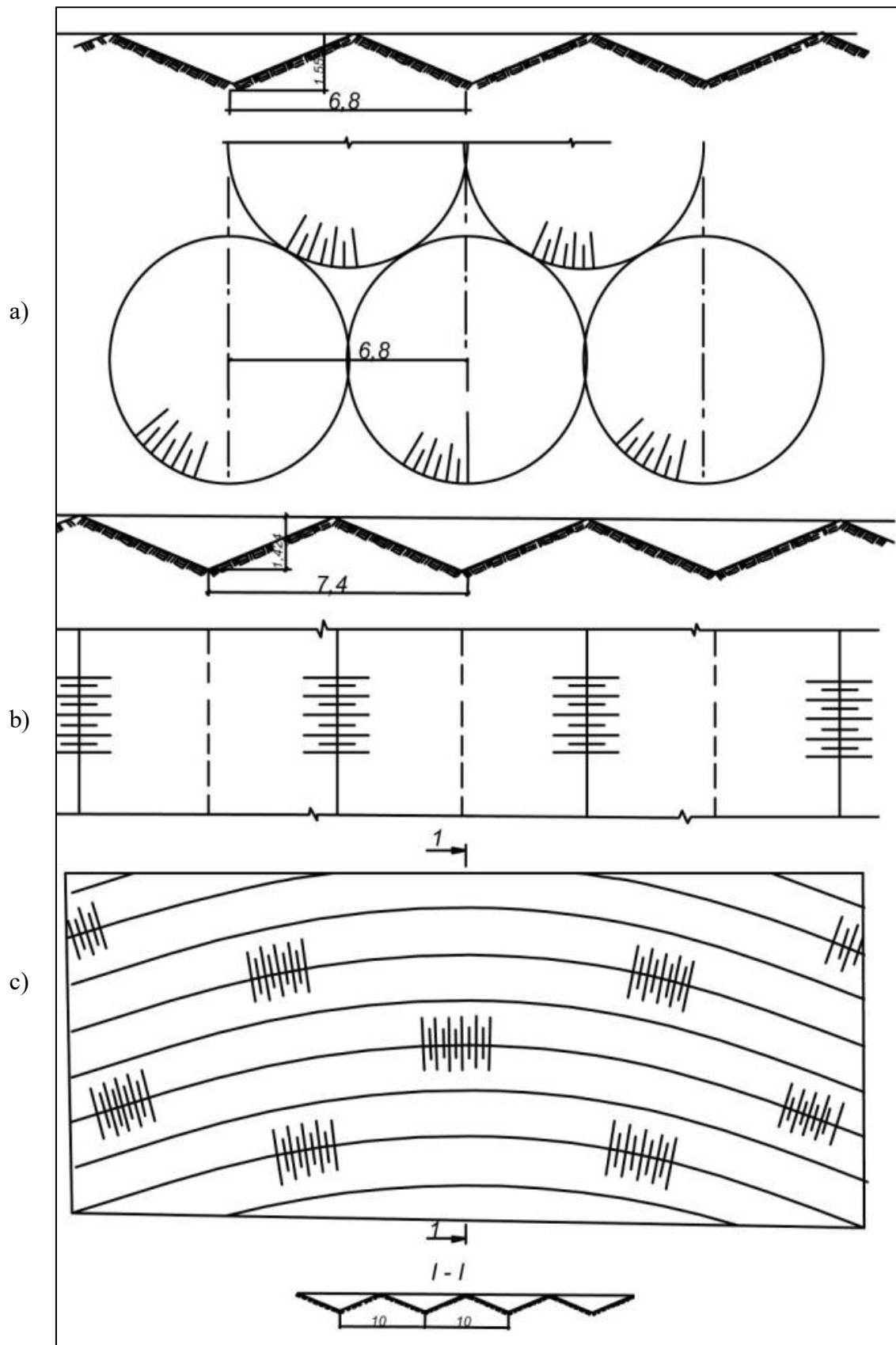

**Figure 6** - Bottom contours of excavations using separate funnels (a), longitudinal trenches (b), and papillonation strips (c) (author's material)

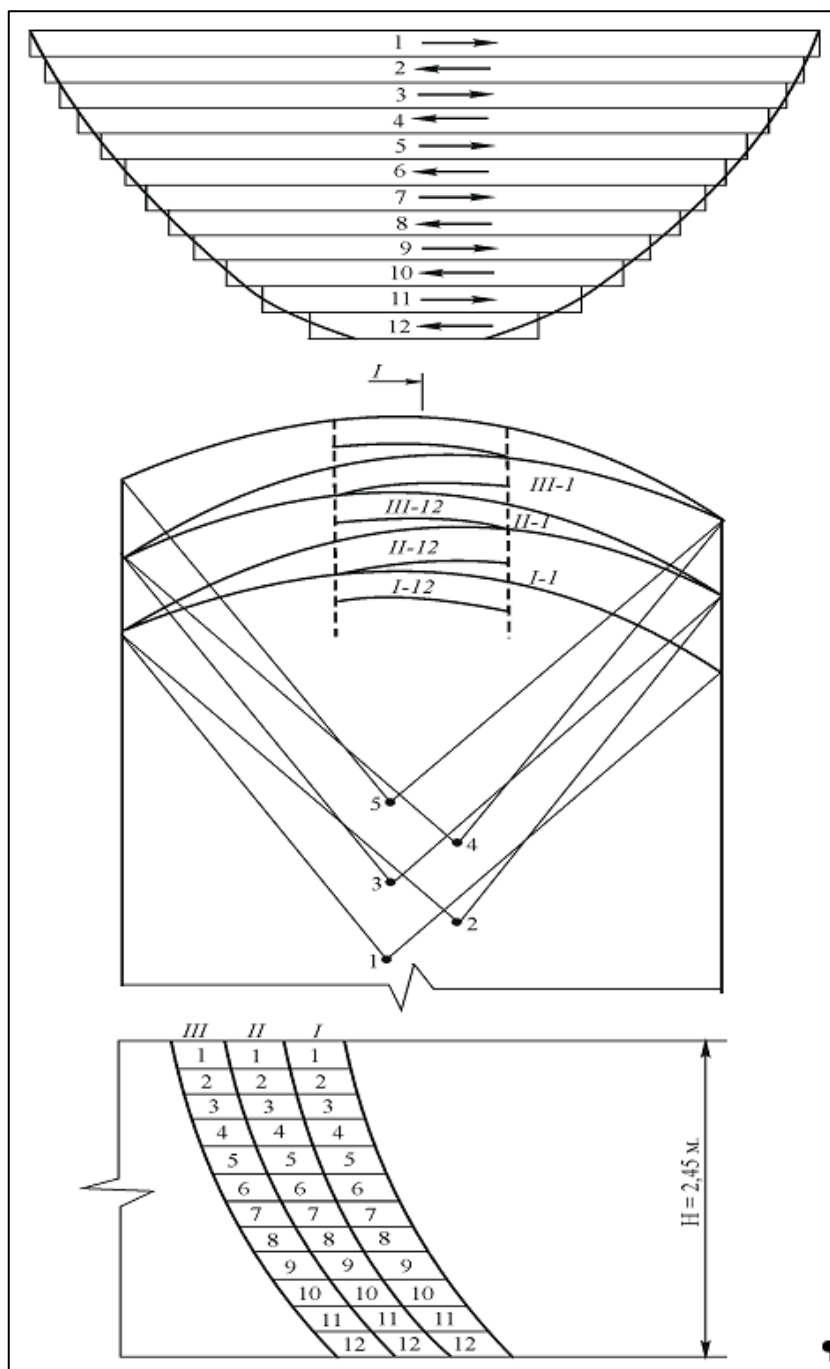

**Figure 7** - Technological scheme for constructing a curvilinear canal using a dredger with papillonation strips (author's material)

Giving the developed canal a cross-sectional shape that is stable in both hydraulic and static aspects has allowed for the following benefits:

- Increased sediment transport capacity of the flow, while simultaneously reducing the cross-sectional area, growth of vegetation, water level fluctuations, water losses, and the right-of-way strip.
- Reduced the volume of cleaning work by up to 20%.
- Increased the period between cleanings by ensuring uniform flow movement.
- Enhanced the productivity of dredgers by concentrating sediment on the canal slopes without changing the overall volume of cleaning.

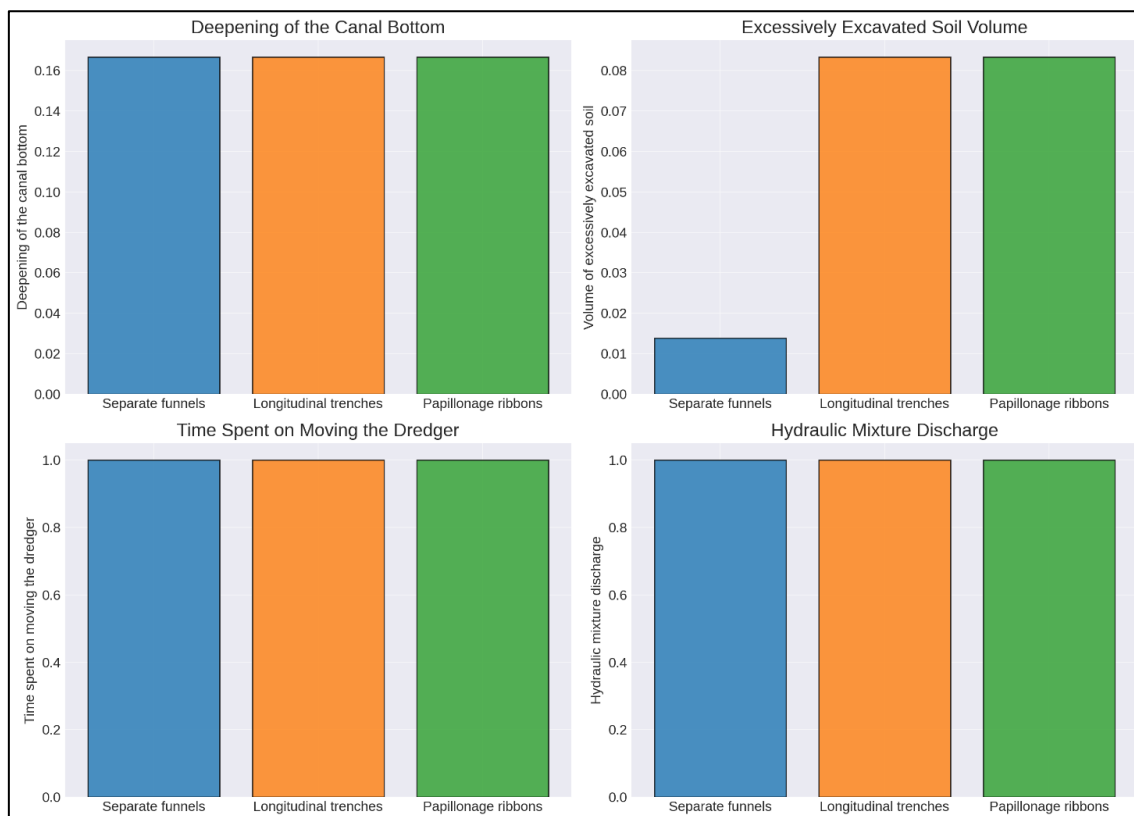

**Figure 8** - Establishing technological parameters for various work methods using dredgers (author's material)

## 5 CONCLUSIONS

1. An analysis of operational activities carried out on the canals of the hydro-reclamation systems of the Republic of Kazakhstan indicates a significant increase over the past 10 years in the volume of cleaning works (by 3.5 times) and the costs of their implementation (by 6 times). The costs of performing cleaning works in the republic have exceeded 60% of all operational expenses. This highlights the need to address issues related to reducing the volume, cost, and labor intensity of cleaning works, and improving the quality of operational activities.

2. The study of existing soil development schemes, both during the construction and cleaning of canals using dredgers, indicates the advisability of using the papillation soil development scheme, which significantly improves the quality and reduces the cost of works.

3. The main directions for improving the efficiency of soil development with dredgers during the construction and maintenance of hydro-reclamation system canals in working condition are improving papillation schemes, using reliable control and measuring equipment, and automating the papillation process.

## REFERENCES

1. Novruzova, G.V. (2023). Energy capacity determining of sediment cleaning from concrete-lined channels based on real indicators. *International Journal on Technical and Physical Problems of Engineering*, 15(1), 352–356.
2. Usmonov, T.U., Karimov, M. S., Sh Sharipov, Z., & Usmanov, N. K. (2023). Determination of the absolute and relative soil velocity in the bucket of a rotary wire cleaner. In *IOP Conference Series*:



- Earth and Environmental Science (Vol. 1206). Institute of Physics. <https://doi.org/10.1088/1755-1315/1206/1/012039>
3. Novruzova, G.V. (2022). Cleaning of concrete-lined channels with a large capacity rotary bucket. *Problems of Computational Mechanics and structural strength* (35), 114–127. <https://doi.org/10.15421/422221>
  4. Naumova, T.V., Kusher, A.M., & Pikalova, I.F. (2019). Improving the efficiency of operational measures on reducing the sediment capture in the irrigation system water intake. *Vestnik MGSU*, (9), 1167–1179. <https://doi.org/10.22227/1997-0935.2019.9.1167-1179>
  5. Lee, A., Usmonov, T., & Norov, B. (2020). Seiling and cleaning of channels. In *IOP Conference Series: Materials Science and Engineering* (Vol. 883). IOP Publishing Ltd. <https://doi.org/10.1088/1757-899X/883/1/012062>
  6. Moldamuratov, Zh.N. (2020). Methods of cleaning channels with dredging shells. *Bulletin of Kazakh Leading Academy of Architecture and Construction*, 78(12), 221–227. <https://doi.org/10.51488/1680-080x/2020.4-32>
  7. Boutsoukis, C., & Arias-Moliz, M.T. (2022). Present status and future directions – irrigants and irrigation methods. *International Endodontic Journal*. John Wiley and Sons Inc. <https://doi.org/10.1111/iej.13739>
  8. Pishgar, R., Keshavarzi, A.R., & Aslani-Kordkandi, A. (2022). An efficient self-cleaning Dam-Type Sediment Excluder upstream of the dam reservoir. *Acta Geophysica*, 70(5), 2389–2401. <https://doi.org/10.1007/s11600-022-00855-y>
  9. Rakhmanin, Y.A., Kuznetsova, K.Y., Kuznetsova, M.A., Gorenkov, R.V., Tararikov, O.Y., & Drozdov, A.A. (2020). Best available technologies: Selection of domestic disinvasion products in the treatment of industrial wastewater and their sediments. *Gigiena i Sanitariya*, 99(12), 1324–1329. <https://doi.org/10.47470/0016-9900-2020-99-12-1324-1329>
  10. Shaazizov, F., Badalov, A., Shukurov, D., & Yulchiev, D. (2020). Hydraulic elevator for cleaning sediment of a water outlet of a reservoir. In *IOP Conference Series: Materials Science and Engineering* (Vol. 883). IOP Publishing Ltd. <https://doi.org/10.1088/1757-899X/883/1/012018>
  11. Tarasyants, S.A., Shiryaev, V.N., Mikheev, A.V. (2021). Methodology for calculating jet ejectors, used in hydromechanization. *Ecology and Water Management*, (2). <https://doi.org/10.31774/2658-7890-2021-3-2-113-123>
  12. **Kadirova, M. G.** (2023). Autoregulatory of water level for channels of parabolic section and its capacity. In *E3S Web of Conferences* (Vol. 401). EDP Sciences. <https://doi.org/10.1051/e3sconf/202340101038>
  13. **Wen, H., & Li, F.** (2014). Numerical integration method for calculating water surface profile of gradually varied steady flow in parabola shaped channel. *Nongye Gongcheng Xuebao/Transactions of the Chinese Society of Agricultural Engineering*, 30(24), 82–86. <https://doi.org/10.3969/j.issn.1002-6819.2014.24.010>
  14. **Zebardast, S., Tabatabaei, S. H., Abbasi, F., Heidarpour, M., Gualtieri, C., Hosseinipour, E. Z., & Asgari, K.** (2015). Analysis of complete mixing length in a non-rectangular channel. In *World Environmental and Water Resources Congress 2015: Floods, Droughts, and Ecosystems - Proceedings of the 2015 World Environmental and Water Resources Congress* (pp. 1998–2003). American Society of Civil Engineers (ASCE). <https://doi.org/10.1061/9780784479162.196>
  15. **Cheng, T., Lu, Q., Kang, H., Fan, Z., & Bai, S.** (2022). Productivity Prediction and Analysis Method of Large Trailing Suction Hopper Dredger Based on Construction Big Data. *Buildings*, 12(10). <https://doi.org/10.3390/buildings12101505>
  16. **Bai, S., Li, M., Kong, R., Han, S., Li, H., & Qin, L.** (2019, September 1). Data mining approach to construction productivity prediction for cutter suction dredgers. *Automation in Construction*. Elsevier B.V. <https://doi.org/10.1016/j.autcon.2019.102833>
  17. **Wang, B., Fan, S. D., Jiang, P., Zhu, H. H., Xiong, T., Wei, W., & Fang, Z. L.** (2020). A novel method with stacking learning of data-driven soft sensors for mud concentration in a cutter suction dredger. *Sensors* (Switzerland), 20(21), 1–19. <https://doi.org/10.3390/s20216075>